



Electric Snow Shovel

Model No. 323E

Form No. 323E-880E

A Division of Snow Joe, LLC

OPERATOR'S MANUAL

IMPORTANT!

Safety Instructions

All Operators Must Read These Instructions Before Use

Any electrical appliance can be dangerous if used incorrectly. Some of the safety precautions given in this manual apply generally to many appliances. Other warnings are specific to the use of this snow shovel.

General Safety WARNINGS!

You and any other operator of this snow shovel must read, understand and follow these instructions in their entirety, and should re-read them at the start of each snow season. Failure to follow these instructions may result in ELECTRIC SHOCK, FIRE and/or serious PERSONAL INJURY.

Notice the personal safety alert symbol  used in this manual to draw your attention to a WARNING given along with the particular operating instruction. This means that the operation requires special ATTENTION, CAUTION, and AWARENESS.

- 1. Replacement parts** – When servicing use only identical replacement parts. Replace or repair damaged cords.

Do not use on gravelled surface unless the snow shovel is adjusted for such a surface in accordance with the operator's manual.
- 2. Keep children and bystander away** – All visitor should be kept at a distance from the work area.
- 3. Dress properly** – Do not wear loose clothing or jewelry. They can be caught in moving parts.

Wear rubber boots when operating the electric snow shovel.

Operation of the electric snow shovel in the hand-held position is unsafe, except in accordance with the special instructions for such use provided in the operator's manual.
- 4. Extension cords** – To prevent disconnection of appliance cord from the extension cord during operation, connect the extension cord to the product as shown on page 6.

 WARNING! – To prevent electric shock, use only with an extension cord suitable for outdoor use.
- 5. Avoid accidental starting** – Don't carry the electric snow shovel with your finger on the switch. Be sure switch is off when plugging in.

If cord is damaged in any manner while plugged in, pull extension cord from wall receptacle.

- 6. Don't abuse cord** – Never carry snow shovel by cord or yank it to disconnect from receptacle. Keep cord from heat, oil, and sharp edges.

Keep hands away from moving parts. Keep guards in place and in working order.
- 7. Don't force snow shovel** – It will perform better and safer at the rate for which it was designed.
- 8. Do not overreach** – Keep proper footing and balance at all times.

If the electric snow shovel strikes a foreign object, follow these steps:

- **Stop the electric snow shovel.**
 - **Inspect for damage.**
 - **Repair any damage before restarting and operating the snow shovel.**
- 9. Disconnect snow shovel** – Disconnect the snow shovel from the power supply when not in use, before servicing, when changing accessories, and the like.
 - 10. Store idle snow shovel indoors** – When not in use, snow shovels be stored indoors in dry, locked place—out of reach of children.
 - 11. Maintain snow shovels with care** – Follow instructions for lubricating and changing accessories.

This electric snow shovel meets or exceeds the B71.3 specifications of the American National Standards Institute in effect at the time of production.

Read and understand the contents of this manual before you start the motor.

 This is the safety alert symbol. It is used to alert you to potential personal injury hazards. Obey all safety messages that follow this symbol to avoid possible injury or death.

Improperly using or maintaining this snow shovel could result in injury or death. To reduce this potential, comply with the following safety instructions.

This electric snow shovel is capable of amputating hands and feet and of throwing objects. Failure to observe the following safety instructions could result in serious injury.

Training

- Read, understand, and follow all instructions on the machine and in the manual(s) before operating this unit. Be thoroughly familiar with the controls and the proper use of the equipment. Know how to stop the unit and disengage the controls quickly.
- Never allow children to operate the equipment. Never allow adults to operate the equipment without proper instruction.
- Keep the area of operation clear of all persons, particularly small children and pets.
- Exercise caution to avoid slipping or falling.

Preparation

- Thoroughly inspect the area where the equipment is to be used and remove all doormats, sleds, boards, wires, and other foreign objects.
- Do not operate the equipment without wearing adequate winter garments. Avoid loose fitting clothing that can get caught in moving parts. Wear footwear that will improve footing on slippery surfaces.
- Do not attempt to clear snow from a gravel or crushed rock surface. This product is intended for use only on paved surfaces.
- Never attempt to make any adjustments while the motor is running (except when specifically recommended by manufacturer).
- Always wear safety glasses or eye shields during operation or while performing an adjustment or repair to protect eyes from foreign objects that may be thrown from the machine.

Operation

- Do not put hands or feet near or under rotating parts. Keep clear of the discharge opening at all times.
- Exercise extreme caution when operating on or crossing gravel drives, walks, or roads. Stay alert for hidden hazards or traffic.
- After striking a foreign object, stop the motor, thoroughly inspect the snow shovel for any damage, and repair the damage before restarting and operating the snow shovel.
- If the unit should start to vibrate abnormally, stop the motor and check immediately for the cause. Vibration is generally a warning of trouble.
- Stop the motor whenever you leave the operating position, before unclogging the rotor blade housing or discharge chute, and when making any repairs, adjustments or inspections.
- When cleaning, repairing, or inspecting the electric snow shovel, stop the motor and make certain that the rotor blades and all moving parts have stopped.
- Exercise extreme caution when operating on slopes.

- Never operate the electric snow shovel without proper guards and other safety protective devices in place and working.
- Never direct the discharge toward people or areas where property damage can occur. Keep children and others away.
- Do not overload the machine capacity by attempting to clear snow at too fast a rate.
- Look behind and use care when backing up with the electric snow shovel.
- Disengage power to the rotor blades when electric snow shovel is transported or not in use.
- Never operate the electric snow shovel without good visibility or light. Always be sure of your footing, and keep a firm hold on the handles. Walk; never run.

Clearing a Clogged Discharge Chute

Hand contact with the rotating rotor blades inside the discharge chute is the most common cause of injury associated with snow shovels. Never use your hand to clean out the discharge chute.

To clear the chute:









- Shut the motor off!
- Wait 10 seconds to be sure the rotor blades have stopped rotating.
- Always use a clean-out tool, not your hands.

Maintenance and Storage

- Check all fasteners at frequent intervals for proper tightness to be sure the equipment is in safe working condition.
- Always refer to the Operator's Manual for important details if the snow shovel is to be stored for an extended period.
- Maintain or replace safety and instruction labels, as necessary.
- Run the machine a few minutes after throwing snow to prevent freeze-up of the rotor blades.

Safety Symbols

The following table depicts and describes safety symbols that may appear on this product. Read, understand, and follow all instructions on the machine before attempting to assemble and operate.

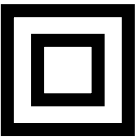
Symbols	Descriptions	Symbols	Descriptions
	Safety Alert. Caution. WARNING! - To reduce the risk of injury, user must read instruction manual.		Electric shock hazard
	Wear hearing protection. Wear eye protection. Wear breathing protection.		DANGER – Keep hands and feet out of openings while the machine is running.
	Do not expose to rain. Keep dry.		Rotating blades. Do not use hands to unclog chute. Stop motor before removing debris.
	Keep the bystander away. Use at a distance of at least 10 m from other people.		Disconnect from supply circuit before opening, cleaning or changing accessories.
	Caution of flying debris.		Double Insulation

Know Your Electric Snow Shovel

Due to modern mass production techniques and product testing, it is unlikely that your power tool is faulty or that a part is missing. If you find anything wrong, do not operate the tool until the parts have been replaced or the fault has been rectified. Failure to do so could result in serious personal injury.

1. Safety button
2. ON/OFF trigger switch
3. Cable restraint hook
4. Adjustable handle
5. Handle knob
6. Wing knob & bolt
7. Snow shovel electrical cord
8. Housing
9. Rotor blades

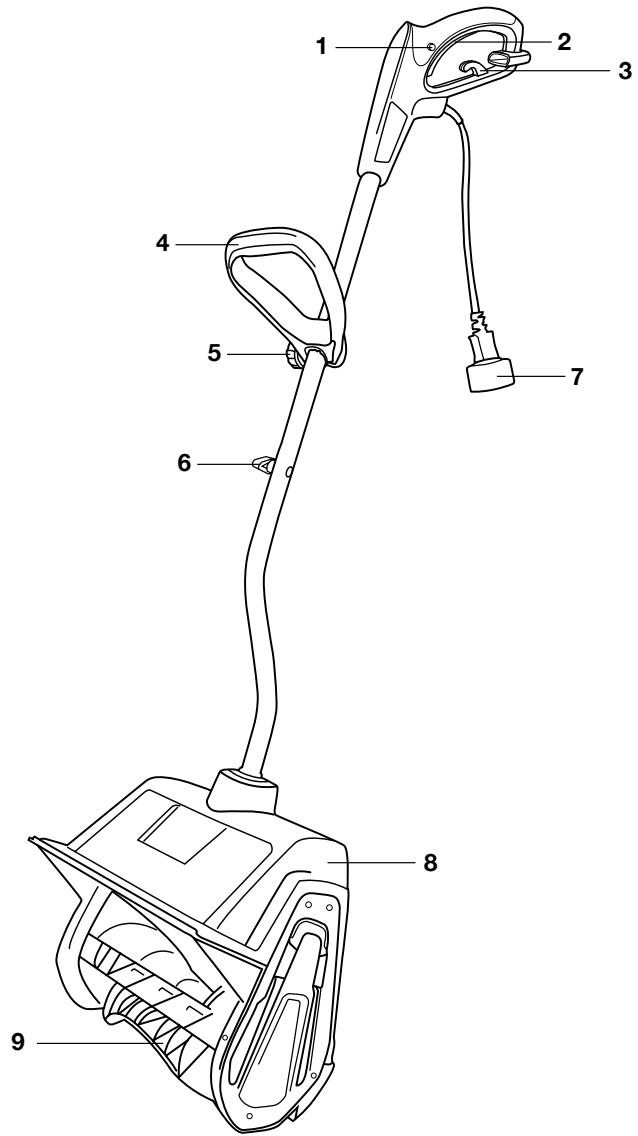

Technical Data

Rated Voltage	120 V ~ 60 Hz	Working Depth	4 in. (10.2 cm)
Rated Power	10 amp	Throw Distance (Max)	20 ft (6 m)
Speed	2150±10 rpm	Plowing Capacity (Max)	400 lbs/min
Working Width	13 in. (33 cm)	Weight	14.7 lbs

Assembly

Upper and Lower Tube Assembly & Positioning The Assist Handle

1. Prior to connecting the upper and lower tube together, slide the assist handle onto the upper tube at the middle section (Fig. 1).

Note: Do not try to install the assist handle after the tubes are assembled.

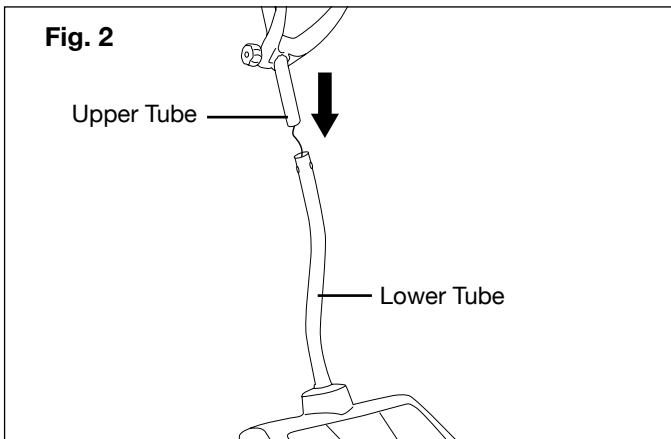
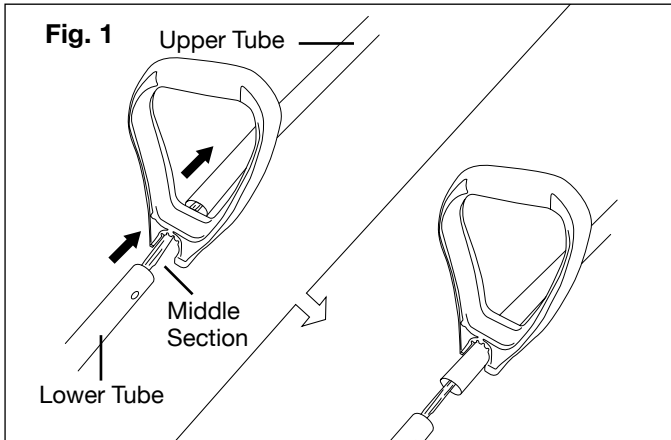

2. After sliding upper tube inside the lower tube (Fig. 2), line up the screw holes on each tube.

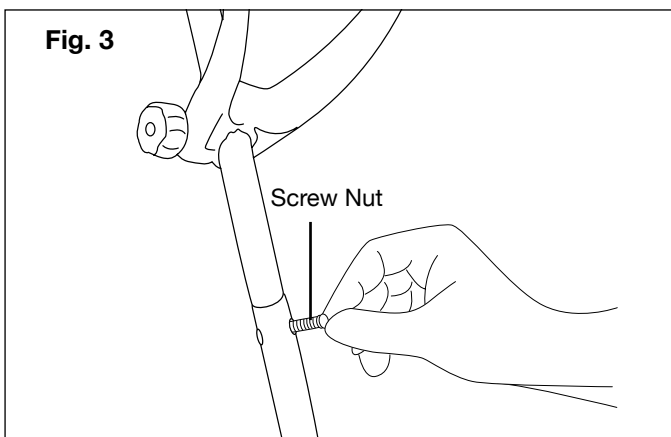

3. Insert the screw nut through the aligned holes in the upper and lower tubes and secure other end with the knob (Fig. 3 and 4).

Note: You may have to carefully move the wiring inside the tube to one side if it blocks the path of the screw. (Use the shipping wire; do not use a sharp tool.)

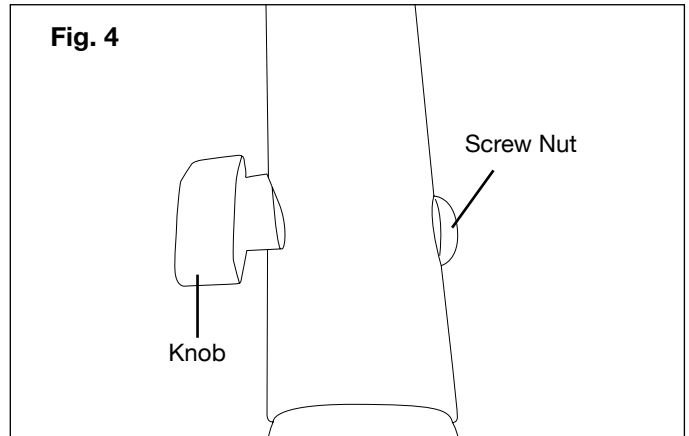

Adjusting the Assist Handle

1. Move and rotate the assist handle to a position that is comfortable for you (Fig. 5).
2. Tighten the knob.

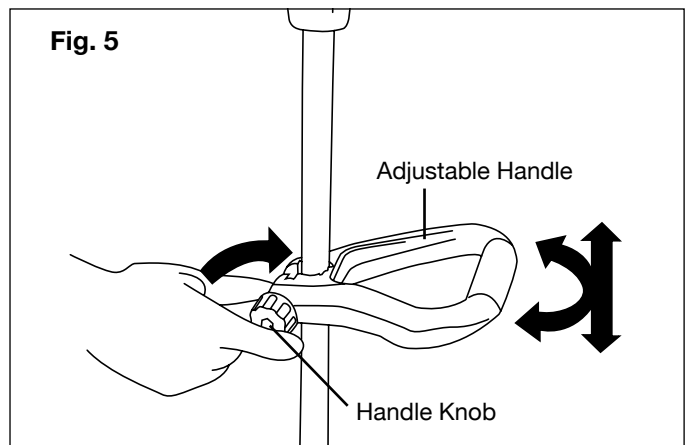

Operation

IMPORTANT: This Electric Snow Shovel is intended for outdoor, residential use only, do not use it indoors or for commercial or industrial purposes.

Connecting to a Power Source

To reduce the risk of electric shock, this appliance has a polarized plug (i.e., one blade is wider than the other; Fig. 6). Use only a polarized plug, UL-listed (CSA certified in Canada) extension cord recommended for outdoor use. A polarized plug will fit in a polarized cord only one way. If the plug does not fit fully in the cord, reverse the cord. If it still does not fit,

purchase a polarized extension cord. If you have a polarized extension cord and the extension cord plug does not fit fully into the wall receptacle, reverse the plug. If it still does not fit, contact a qualified electrician to install the proper outlet. Do not change the appliance or extension cord plug in any way.

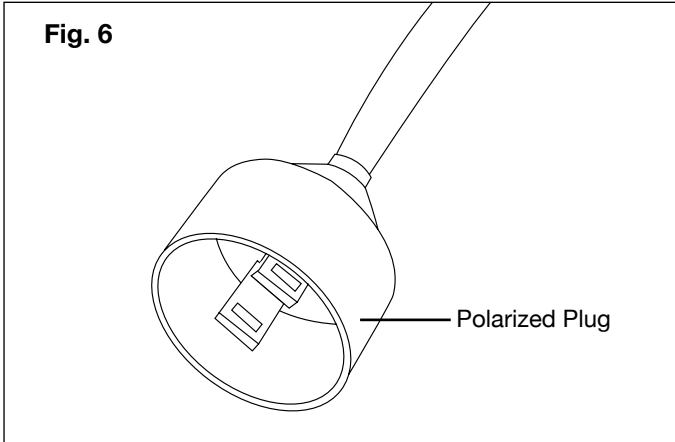

1. Make a loop in the extension cord (Fig. 7).

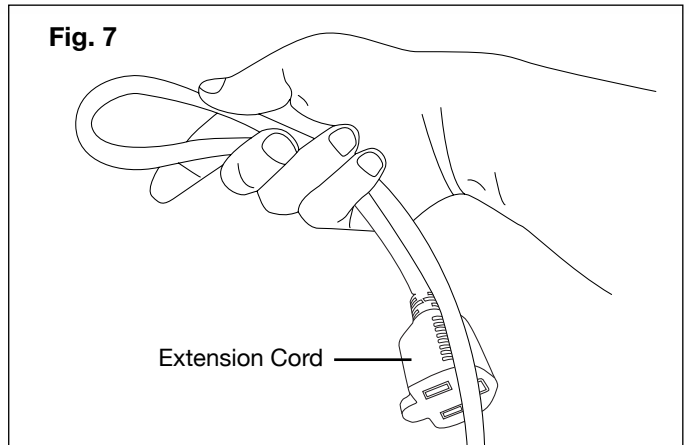

2. Insert the loop through the hole in the back of the upper handle, securing the loop around the hook (Fig. 8).

Note: This helps to prevent you from accidentally disconnecting the extension cord from the appliance during operation.

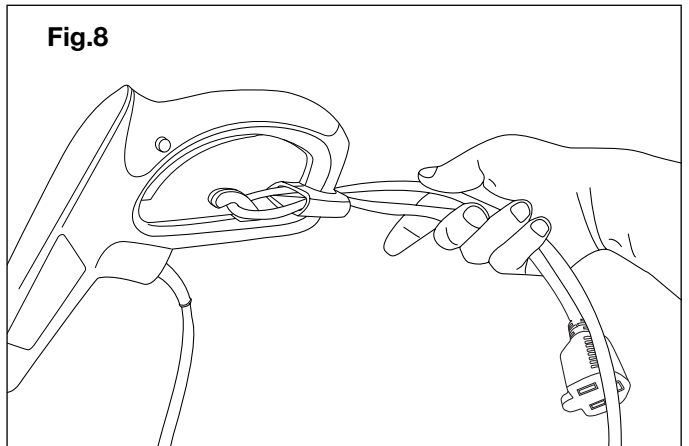

3. Connect the extension cord to the appliance electrical cord (Fig. 9).

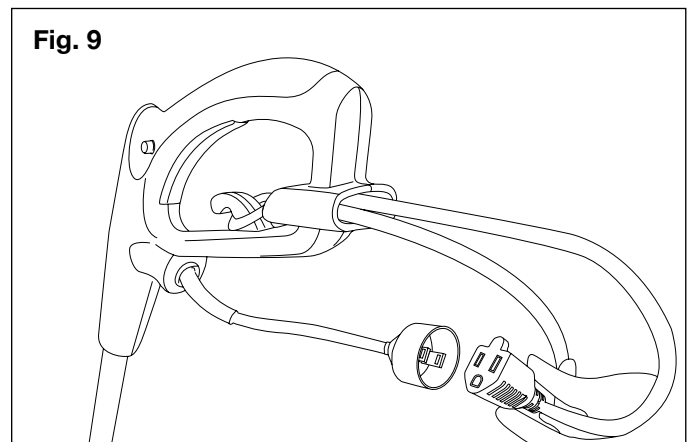

⚠ **WARNING** ⚠

Electric shock may cause SEVERE INJURY or DEATH. Heed these warnings:

- Do not allow any part of snow shovel to make contact with water while powered on. If the appliance becomes wet while turned off, wipe dry before starting.
- Use only a UL-rated extension cord for outdoor, all-weather use. Do not use an extension cord over 150 feet (46 meters).
- Do not touch the appliance or its plug with wet hands or while standing in water. Wearing rubber boots offers some protection.

EXTENSION CORD CHART

Cord Length:	100 ft (30m)	150 ft (46m)
Min. Wire Gauge (A.W.G.):	16	14

IMPORTANT: Check the extension cord frequently during use for holes or cracks in the insulation. Do not use a damaged cord. Do not run the cord through standing water or wet grass.

Use only an extension cord recommended for outdoor use.

4. Plug the extension cord into a wall outlet.
5. Keep the area to be cleared free of stones, toys, or other foreign objects which the rotor blades may pick up and throw. Such items could be covered by snowfall and remain unnoticed.

Starting and Stopping

1. To start the electric snow shovel, push the safety button on the top of the handle grip and squeeze the trigger. You can now release the safety button. To stop the product, release the trigger (Fig. 10).

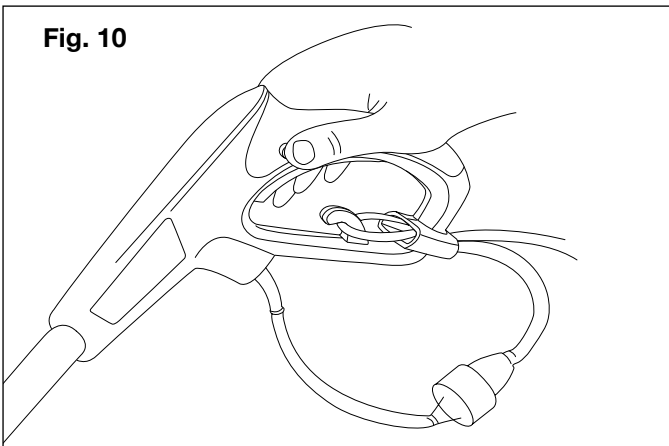

Operating Tips

- Start the electric snow shovel and tilt it forward until the scraper blade contacts the ground. Push the shovel forward at a comfortable rate of speed, yet slow enough to clear the path completely. The width and depth of the snow determines your forward speed.
- Direct the snow to the right or to the left by holding the electric snow shovel at a slight angle.
- For the most efficient snow removal, throw the snow downwind, and slightly overlap each swath.
- If you need to clear snow from crushed rock or gravel, push down on the handle to raise the scraper clear of loose material that the rotor blades could throw.
- The electric snow shovel can remove snow up to 4-IN (10.2 cm) deep in one pass.
- When clearing deeper drifts, hold the electric snow shovel by the upper and lower handles and use a swinging or sweeping motion. Remove a maximum of 13-IN (33 cm) width with each pass and repeat as many times as required.
- Keep the cord clear of obstructions, sharp objects, and rotor. Do not pull sharply on the cord or abuse it in any manner. Frequently inspect the cord for damage. If it is damaged, replace the cord.
- Disconnect the extension cord after using the electric snow shovel. Hang the extension cord with the shovel so it will not be misplaced or damaged.

Maintenance

⚠ WARNING! If the extension cord is plugged into product, someone could accidentally operate it while you are performing maintenance on it, causing serious personal injury.

Disconnect the extension cord before you perform any maintenance.

Replacing the Auger

IMPORTANT: Disconnect the power from the electric snow shovel before performing this procedure.

1. Disassemble the right side cover by removing five screws (Fig. 11).

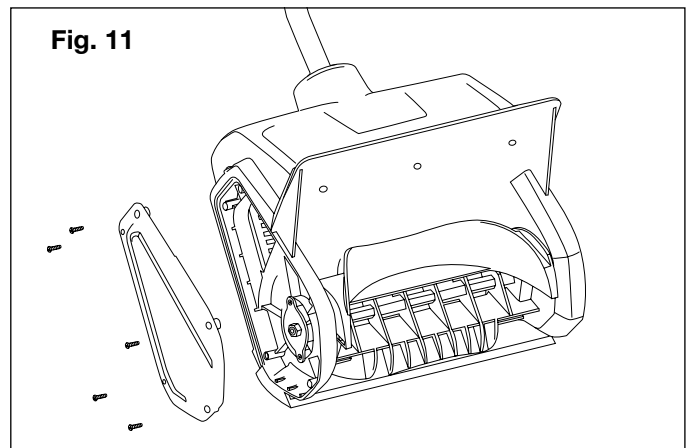

2. Disassemble M10 screw nut (Fig. 12).

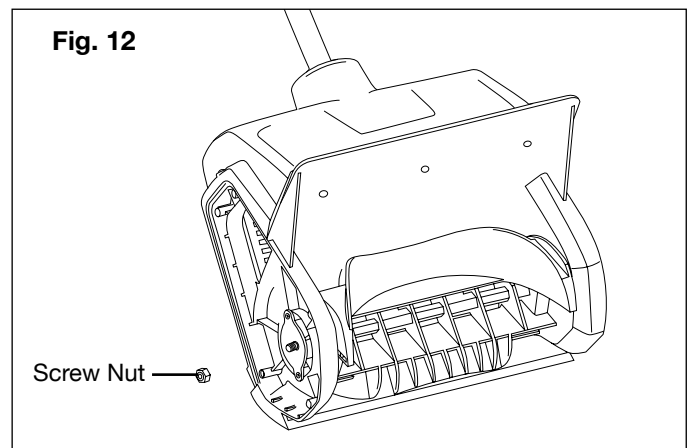

3. Disassemble the left side cover by removing five screws (Fig. 13).

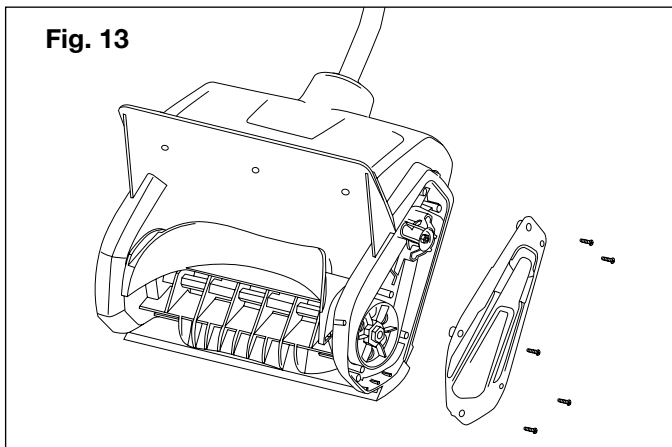

4. Remove the belt from the drive wheel (Fig. 14).

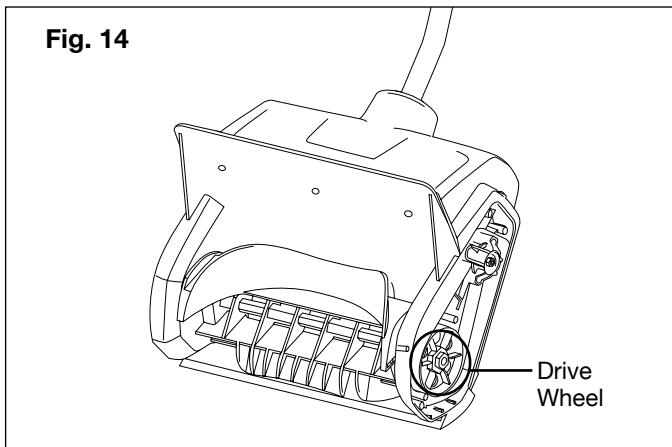

5. Disassemble screws and the bushings from the drive wheel (Fig. 15).

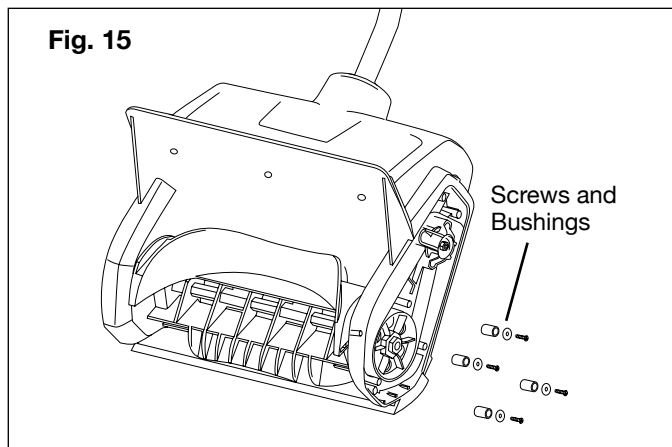

6. Get the auger axle set out (Fig. 16).

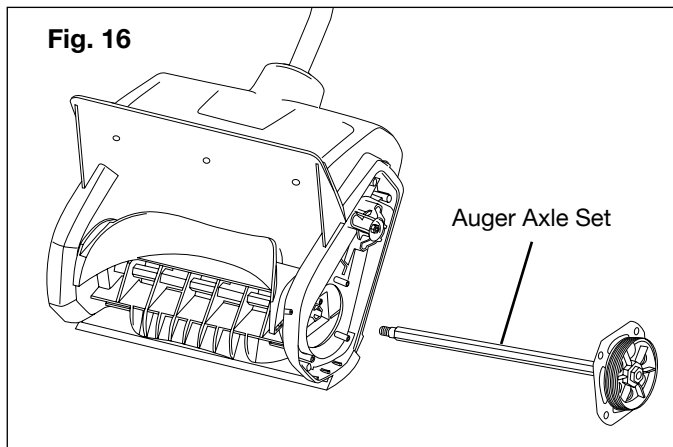

7. Remove the old auger from the housing (Fig. 17).

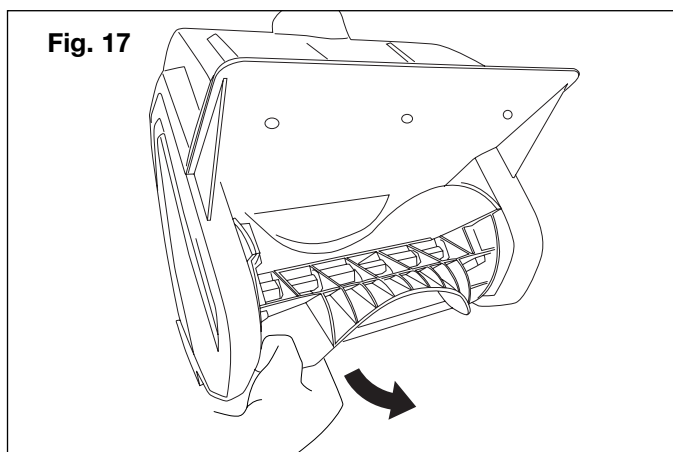

8. Replace the auger (Fig. 18).

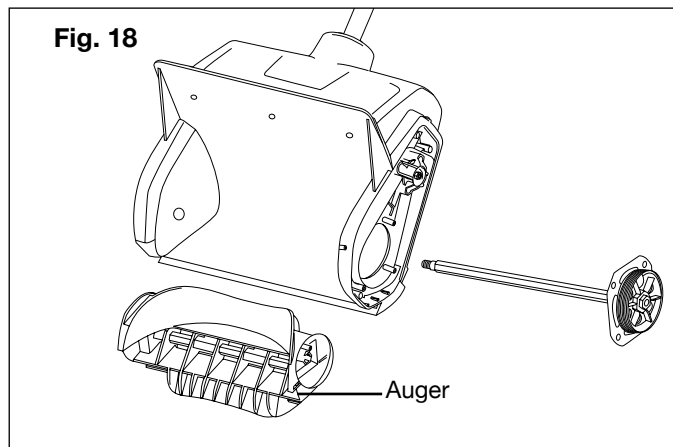

Lubricating the Electric Snow Shovel

The electric snow shovel does not need lubrication; all bearings are lubricated at the factory for the life of the product.

Double-insulated Appliances

In a double-insulated appliance, two systems of insulation are provided instead of grounding. No grounding means is provided on a double-insulated appliance, nor should a means for grounding be added to the appliance. Servicing a double-insulated appliance requires extreme care and knowledge of the system, and should be done only by the qualified service personnel at your Snow Joe Service Dealer. Replacement parts for a double-insulated appliance must be identical to the parts they replace. A double-insulated appliance is marked with the words “Double Insulation” or “Double Insulated.” The symbol  (square within a square) may also be marked on the appliance.

Storage

Store the product and extension cord indoors, in a cool dry location, out of reach of children and animals.

Note: Devices for retaining extension cords are commercially available.

1. Examine the electric snow shovel thoroughly for worn, loose, or damaged parts. If parts repair or replacement is necessary, contact an Authorized Service Dealer for assistance.
2. Examine the extension cord thoroughly for signs of excess wear or damage. If it is worn or damaged, replace it.
3. Disconnect the extension cord from the electric snow shovel before storing.
4. Store the electric snow shovel in a clean, dry, locked-up place out of the reach of children and cover it to provide protection.
5. Store the product and extension cord indoors, in a cool dry location, out of reach of children and animals.

Note: Devices for retaining extension cords are commercially available.

Service and Support

If your Snow Joe 323E electric snow shovel requires service or maintenance, please call 1-866-SNOWJOE for assistance.

Model and Serial Numbers

When contacting the company, reordering parts, or arranging model and serial numbers, which are found on the decal on the housing. Copy these numbers into the space provided below.

Please record the following numbers from the housing or handle of your new product:

Model #:

Serial #:



A Two-Year Full Warranty for residential use in the United States and Canada



General Conditions:

Snow Joe®, LLC warrants this product to the original purchaser for two years against defects in material or workmanship when used for normal residential purposes. Snow Joe®, LLC will repair any defect in material or workmanship, and repair or replace any defective part, subject to the conditions, limitations, and exclusions set forth herein. Such repair or parts replacement will be free from charge to the original purchaser except noted below.

The duration of the warranty applies only if the product is put to personal use around the household or residence. If the product is put to any business use, commercial or industrial, then the duration of this warranty is 90 days from the date of original purchase. If any product is rented or leased, the duration of the warranty is 90 days from the date of original purchase.

It is the owner's responsibility to perform correctly all maintenance, and minor adjustments explained in the owner's manual.

Electric Products:

To obtain a replacement electric powered unit or repair the existing electric powered unit, you must return the complete unit and postage prepaid to: **Snow Joe Return Center, 86 Executive Avenue, Edison, NJ 08817.**

Gasoline / Battery Products:

Limitations

- Batteries are warranted only for the period of 12 months after the date of purchase on a prorated basis. Rechargeable batteries will be replaced free from charge during the first 90 days. After the initial 90 days, batteries will be replaced at a prorated cost to the customer.
- Idlers, cables, and electrical components are warranted to the original purchaser for use at household or residence for a period of two years.

Exclusions

- Snow Joe® brand engines are covered under this warranty. All other engines and engine accessories are covered only by the engine manufacturer's warranty and are not covered by this warranty.
- Parts used that are not genuine Snow Joe® parts are not covered by this warranty.
- Damages resulting from misuse, alteration, improper assembly, improper adjustment, neglect, or accident which requires repair is not covered under this warranty.
- Belts, augers, and tines are not covered under warranty – belts, augers, and tines wear out and can be purchased at www.snowjoe.com or by calling 1-866-766-9563.

Snow Joe®, LLC may from time to time change the design of its products. Nothing contained in this warranty shall be construed as obligating Snow Joe®, LLC to incorporate such design changes into previously manufactured products, nor shall such changes be construed as an admission that previous designs were defective.

This warranty is intended to cover product defects only. Snow Joe®, LLC is not liable for indirect, incidental, or consequential damages in connection with the use of the Snow Joe® Products covered by this warranty. This warranty does not cover any cost or expense incurred by the purchaser in providing substitute equipment or service during reasonable periods of malfunction or non-use of this product, while waiting for completion of repairs under this warranty. Some states do not allow exclusions of incidental or consequential damages, so the above exclusions may not apply in all states. This warranty may give you specific legal rights in your state.

**If you wish to contact Snow Joe®, please direct inquiries to the:
Customer Service Department
Snow Joe Center
86 Executive Avenue
Edison, NJ 08817**

Customers who have purchased Snow Joe® products exported from the United States and Canada should contact their Snow Joe® Distributor (Dealer) to obtain information applicable for your country, province, or state. If for any reason, you are not satisfied with the distributor's service, or if you have difficulty obtaining warranty information, contact your Snow Joe® seller. If in the event your efforts are unsatisfactory, please write to the Snow Joe® Center at the above address.

If you have any questions about your product warranty, please call 1-866-SNOW-JOE or visit us online at www.snowjoe.com.